

SENTRIGARD FP100 SERIES WALL PANELS

24 Ga. STEEL PANELS OVER 1/2" PLYWOOD

GENERAL NOTES:

1. THIS SYSTEM HAS BEEN DESIGNED AND TESTED TO MEET ALL OF THE REQUIREMENTS OF THE 8TH EDITION (2023) FLORIDA BUILDING CODE, INCLUDING THE HIGH VELOCITY HURRICANE ZONE (HVHZ) PROVISIONS.
2. THIS SYSTEM HAS BEEN TESTED PER TAS 201, 202, AND 203 FOR (LEVEL D) LARGE AND SMALL MISSILE IMPACT RESISTANCE. SHUTTERS ARE NOT REQUIRED IN WINDBORNE DEBRIS REGIONS.
3. THIS SYSTEM HAS BEEN DESIGNED FOR INSTALLATION OVER 1/2" (15/32" MIN) 4-PLY CDX PLYWOOD SHEATHING, SUPPORTED BY WOOD OR METAL STUDS. THE WOOD OR METAL STUD WALL IS NOT A PART OF THIS APPROVAL. THE WALL SYSTEM MUST ADEQUATELY SUPPORT THE LOADS IMPOSED BY THE PANEL SYSTEM AND TRANSFER THEM SAFELY TO THE BUILDING STRUCTURE.
4. THIS IS A RAINSCREEN SYSTEM. A WEATHER-RESISTIVE BARRIER MEETING THE REQUIREMENTS OF FBC SECTION 1404.2, WITH FLASHING MEETING 1405.4, MUST BE INSTALLED BEHIND THIS SYSTEM.
5. DESIGN LOADS MUST BE CALCULATED BY A PROFESSIONAL ENGINEER OR ARCHITECT FOR EACH PROJECT. THE (ASD) PROJECT PRESSURE CANNOT EXCEED THE DESIGN PRESSURES LISTED IN THE TABLE ON THIS SHEET.
6. ALL ANCHORS SECURING THE SYSTEM TO PRESSURE TREATED WOOD SHALL BE CAPABLE OF RESISTING CORROSION CAUSED BY THE CHEMICALS IN THE WOOD.
7. MATERIALS INCLUDING BUT NOT LIMITED TO STEEL/METAL SCREWS THAT COME INTO CONTACT WITH OTHER DISSIMILAR MATERIALS SHALL BE PROTECTED PER FBC REQUIREMENTS.
8. NO INCREASE IN ALLOWABLE STRESS HAS BEEN USED IN THE DESIGN OF THIS PRODUCT. Cd=1.6 WAS USED FOR WOOD SCREWS ONLY.
9. PANELS ARE MADE FROM 24 Ga. STEEL (Fy = 61 ksi min), GALVANIZED TO MEET ASTM A525 G90.
10. PANELS ARE FASTENED TO THE 1/2" PLYWOOD SHEATHING WITH #12-11 x 1" PANCLIP MTW WOOD SCREWS BY DMI (OR EQUAL). SCREWS MAY BE CARBON STEEL WITH DMG85 SILVER COATING OR 316 SERIES STAINLESS STEEL.

FASTENER SPACING (in)	MAXIMUM DESIGN PRESSURE (+/- psf)
6	186
12	94
24	47
36	31
48	23

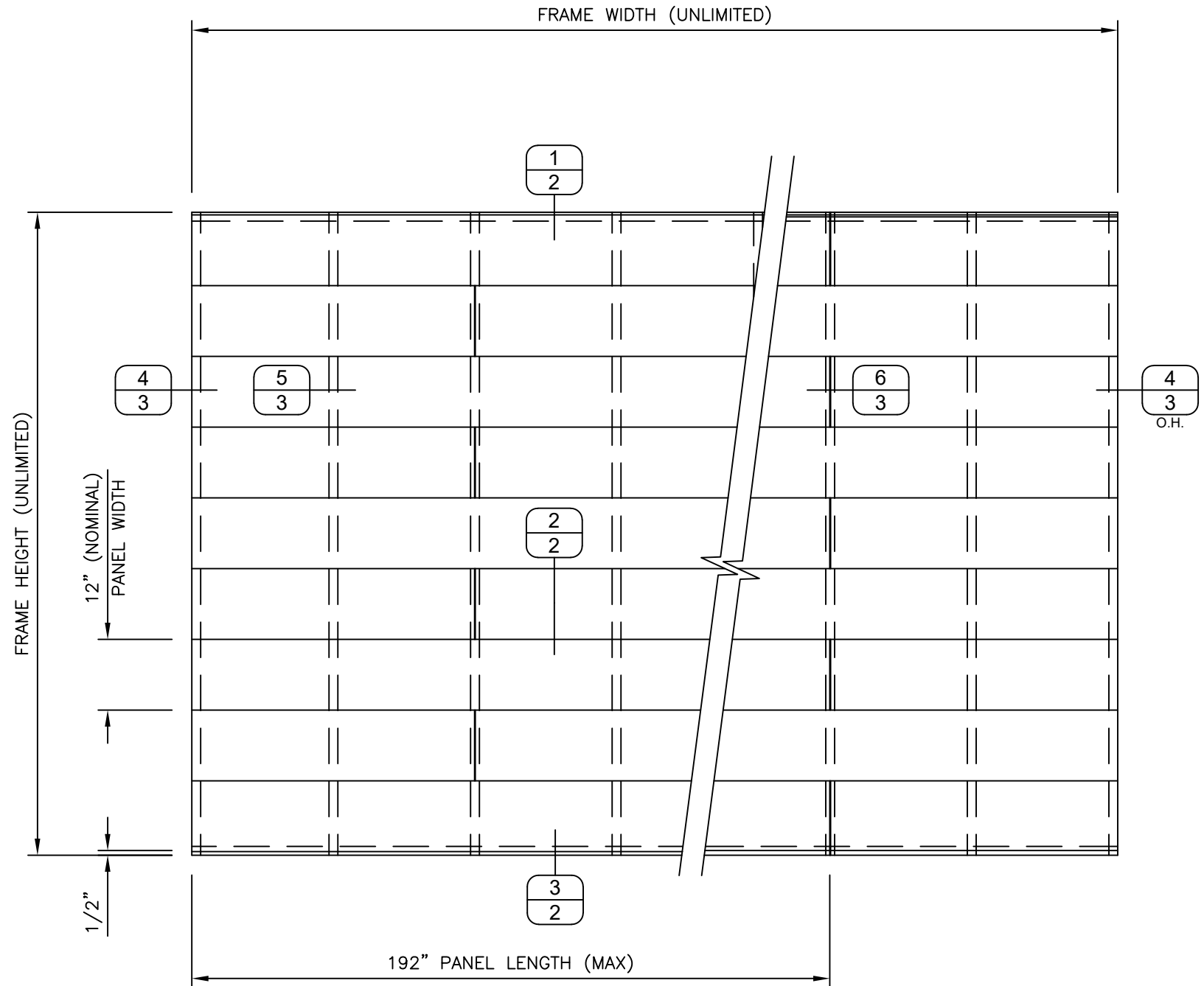

**EXTERIOR VIEW
(NOT TO SCALE)**

DATE	4/16/26
REV.#	
PRINTS ISSUED	FDR
1ST SUBMITTAL	

SENTRIGARD
METAL ROOFING SYSTEMS

PH: (434) 847-2445
www.sentrigard.com

65 10TH STREET
LYNCHBURG, VA 24504

SEAL:

SCOTT WOLTERS
FL PE# 62354

WOLTERS ENGINEERING
(CO.# 27194)
15211 97TH ROAD N
WEST PALM BEACH, FL 33412
PH/FAX:(561) 225-1982

SCOTT WOLTERS
LICENSE
NO 62354
STATE OF FLORIDA
APR 16 2025
PROFESSIONAL ENGINEER

DWG: **FP100SW-HZ**

SHEET: **1/4**

SENTRIGARD FP100 SERIES WALL PANELS

24 Ga. STEEL PANELS OVER 1/2" PLYWOOD

FASTENER SPACING (in)	MAXIMUM DESIGN PRESSURE (+/- psf)
6	186
12	94
24	47
36	31
48	23

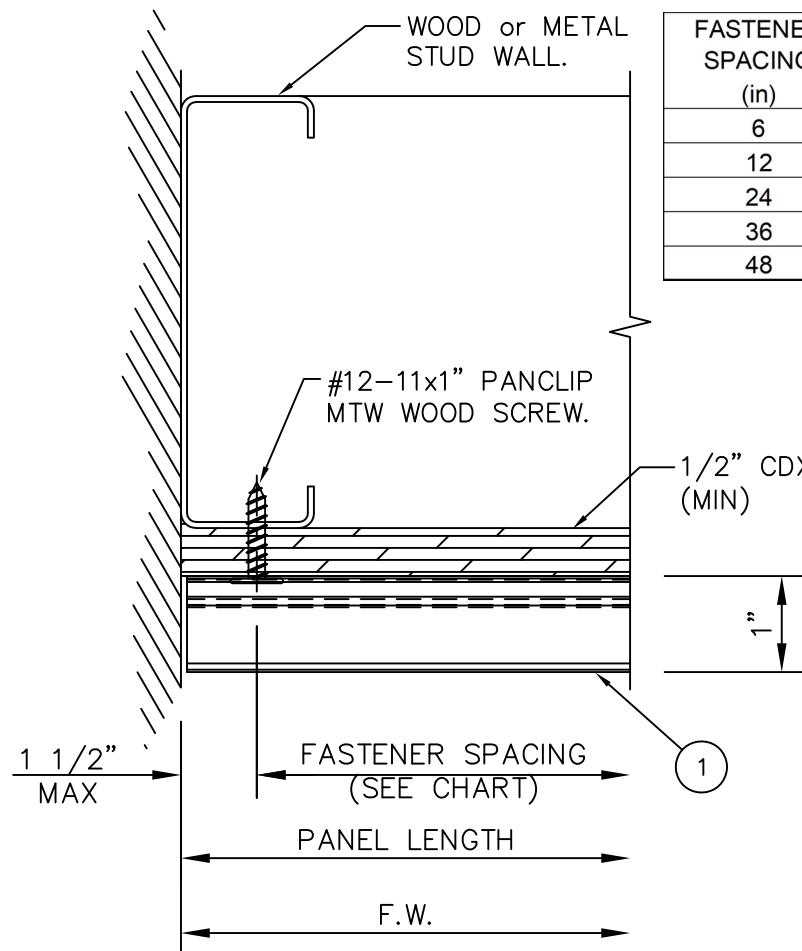

4 JAMB

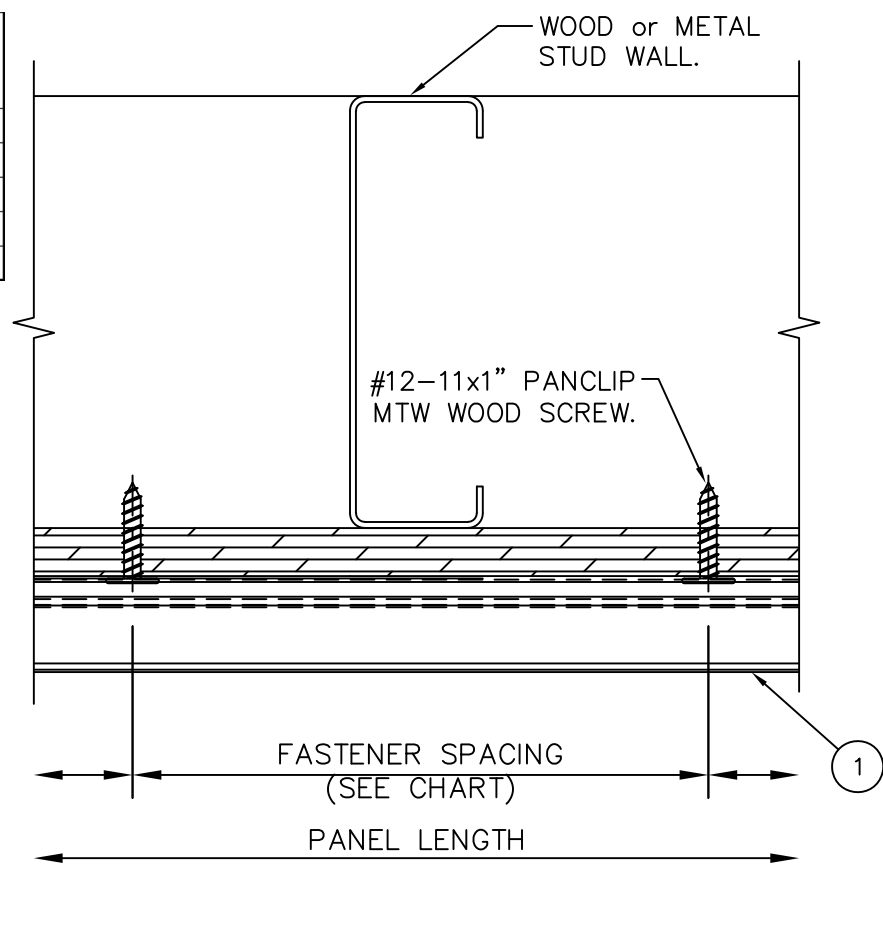

5 VERT

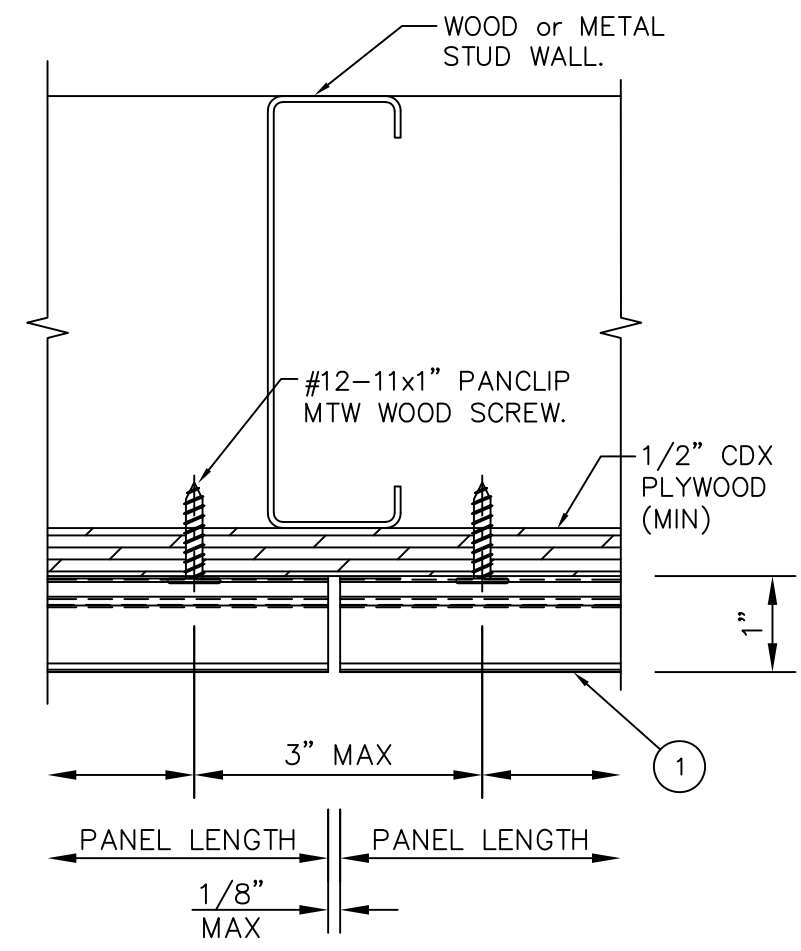

6 JOINT

ALTERNATE DETAILS (CONCRETE/CMU)

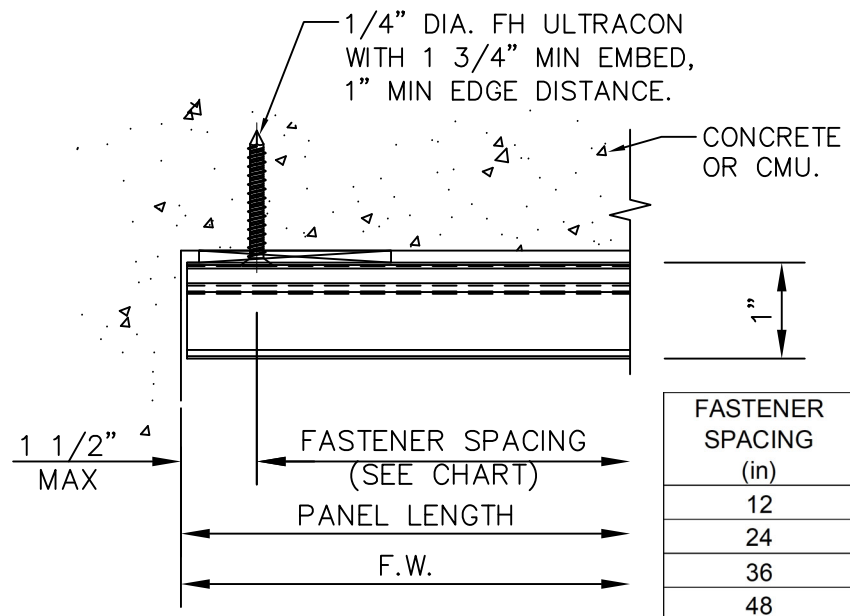

FASTENER SPACING (in)	MAXIMUM DESIGN PRESSURE (+/- psf)
12	186
24	120
36	97
48	86

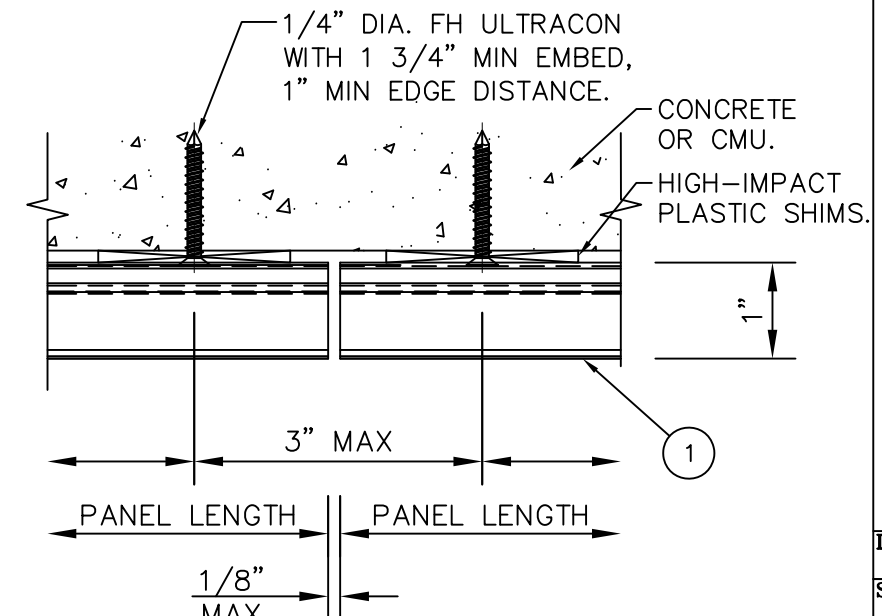
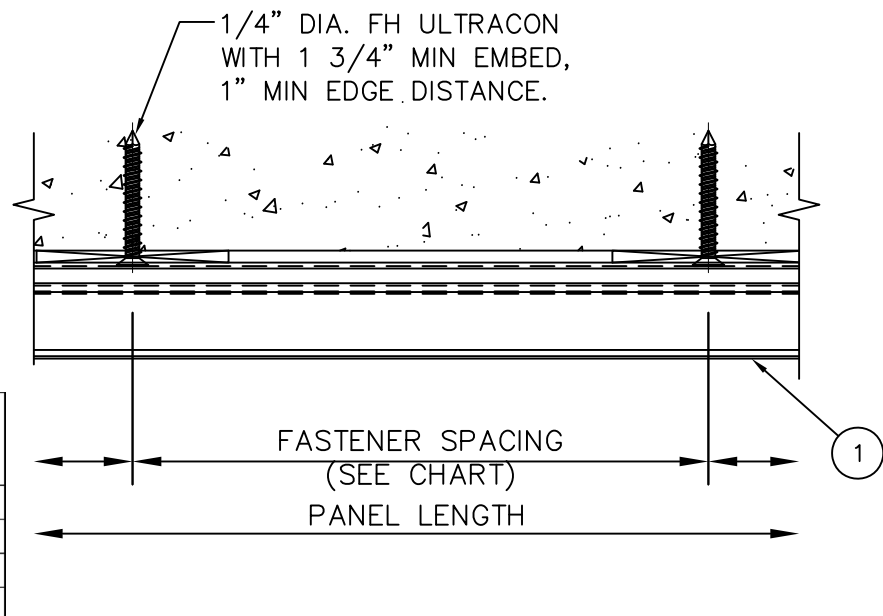

REV.#	DATE
1	4/16/26

SENTRIGARD
METAL ROOFING SYSTEMS

PH: (434) 847-2445
www.sentrigard.com

65 10TH STREET
LYNCHBURG, VA 24504

SEAL: SCOTT WOLTERS, FL PE# 62354, LICENSE NO. 62354, STATE OF FLORIDA, PROFESSIONAL ENGINEER, APR 16 2025

WOLTERS ENGINEERING (CO.# 27194)
15211 97TH ROAD N
WEST PALM BEACH, FL 33412
PH/FAX: (561) 225-1982

DWG: FP100SW-HZ
SHEET: 3/4

SENTRIGARD FP100 SERIES WALL PANELS

24 Ga. STEEL PANELS OVER 1/2" PLYWOOD

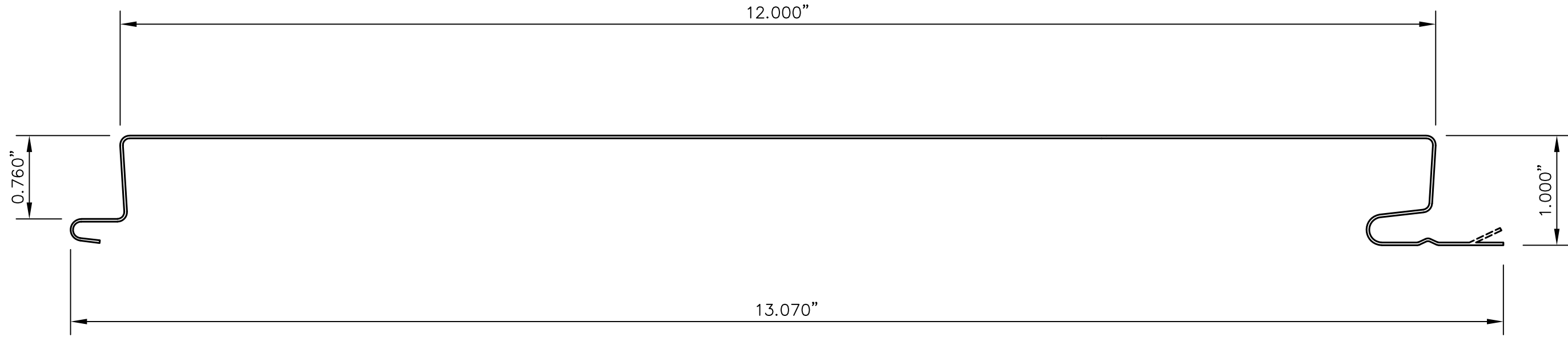

1

24 Ga. STEEL
(Fy=61 ksi MIN)

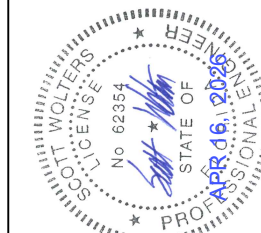

SEAL:
SCOTT WOLTERS
FL PE# 62354
WOLTERS ENGINEERING
(COA# 27194)
15211 97TH ROAD N
WEST PALM BEACH, FL 33412
PH/FAX: (561) 225-1982

DWG: **FP100SW-HZ**

SHEET: **4/4**



SENTRIGARD
METAL ROOFING SYSTEMS

65 10TH STREET
LYNCHBURG, VA 24504

PH: (434) 847-2445
www.sentrigard.com

REV.#	ISSUED FOR	DATE
1	1ST SUBMITTAL	4/16/26
2	PRINTS	
3	ISSUED FOR	
4		
5		
6		
7		
8		
9		
10		