

# SENTRIGARD FP100 SERIES WALL PANELS

24 Ga. STEEL PANELS OVER 16 Ga. STEEL PURLINS

## GENERAL NOTES:

1. THIS SYSTEM HAS BEEN DESIGNED AND TESTED TO MEET ALL OF THE REQUIREMENTS OF THE 8TH EDITION (2023) FLORIDA BUILDING CODE, FOR USE OUTSIDE OF THE HIGH VELOCITY HURRICANE ZONE (HVHZ).
2. THIS SYSTEM HAS BEEN TESTED PER TAS 202. THIS SYSTEM HAS NOT BEEN TESTED FOR IMPACT RESISTANCE, SHUTTERS ARE REQUIRED IN WINDBORNE DEBRIS REGIONS.
3. THIS SYSTEM HAS BEEN DESIGNED FOR INSTALLATION OVER OPEN 16 Ga. STEEL PURLINS (Fut = 45 ksi min). THE PURLINS MUST ADEQUATELY SUPPORT THE LOADS IMPOSED BY THE PANEL SYSTEM AND TRANSFER THEM SAFELY TO THE BUILDING STRUCTURE.
4. DESIGN LOADS MUST BE CALCULATED BY A PROFESSIONAL ENGINEER OR ARCHITECT FOR EACH PROJECT. THE (ASD) PROJECT PRESSURE CANNOT EXCEED THE DESIGN PRESSURES LISTED IN THE TABLE ON THIS SHEET.
5. ALL ANCHORS SECURING THE SYSTEM TO PRESSURE TREATED WOOD SHALL BE CAPABLE OF RESISTING CORROSION CAUSED BY THE CHEMICALS IN THE WOOD.
6. MATERIALS INCLUDING BUT NOT LIMITED TO STEEL/METAL SCREWS THAT COME INTO CONTACT WITH OTHER DISSIMILAR MATERIALS SHALL BE PROTECTED PER FBC REQUIREMENTS.
7. NO INCREASE IN ALLOWABLE STRESS HAS BEEN USED IN THE DESIGN OF THIS PRODUCT. Cd=1.6 WAS USED FOR WOOD SCREWS ONLY.
8. PANELS ARE MADE FROM 24 Ga. STEEL (Fy = 61 ksi min), GALVANIZED TO MEET ASTM A525 G90.
9. PANELS ARE FASTENED TO THE 16 Ga. PURLINS WITH #8-18 x 3/4" PAN FLAT HEAD TEKS SCREWS (OR EQUAL). (1) FASTENER AT JAMBS, (1) PER PURLIN FOR 12" PURLIN SPACING, (2) PER PURLIN FOR 60" PURLIN SPACING, AND (2) PER PURLIN AT PANEL JOINTS.

PURLIN SPACING (in)	MAXIMUM DESIGN PRESSURE (+/- psf)
12	100
60	26.6

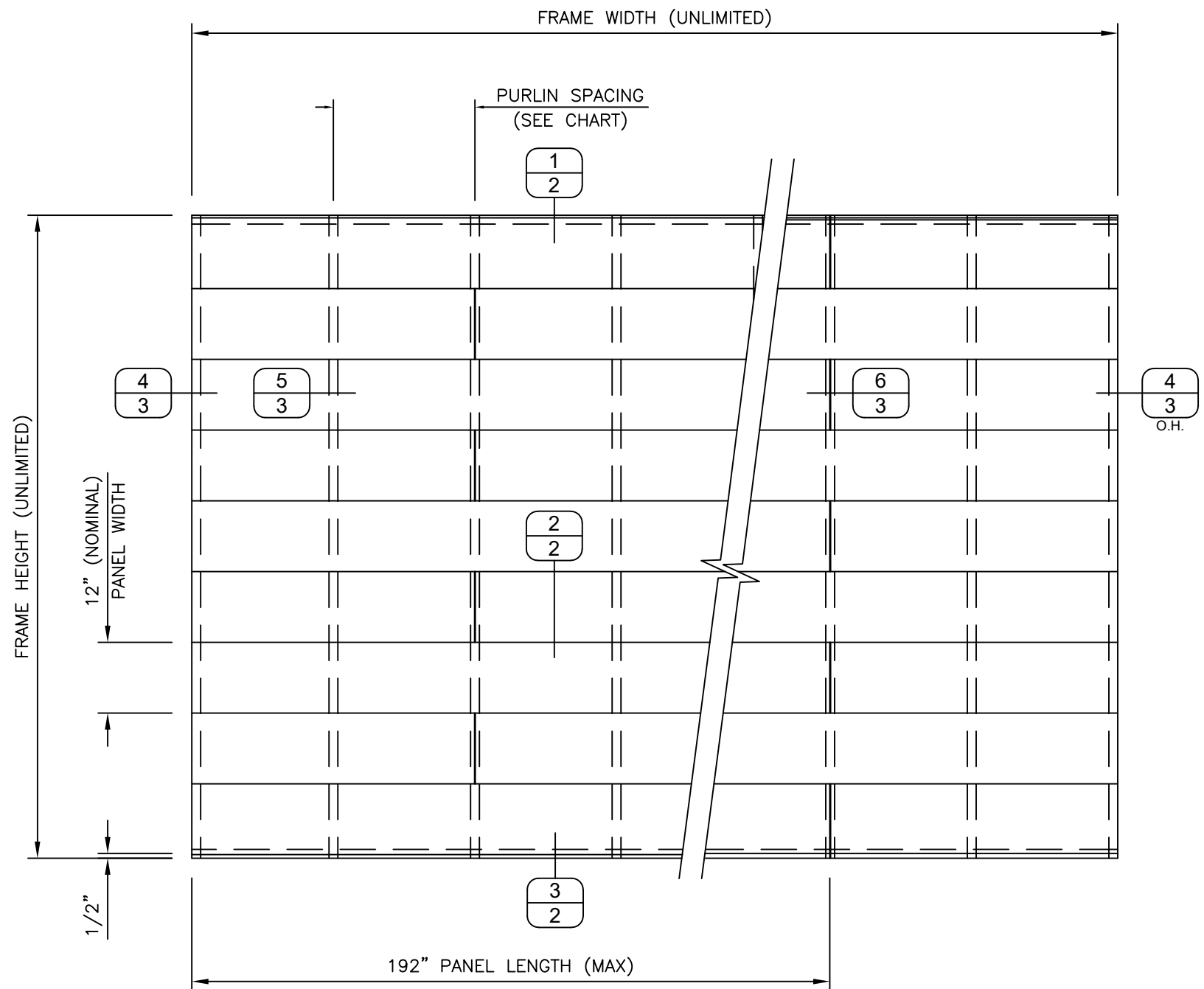

**EXTERIOR VIEW  
(NOT TO SCALE)**

REV.#	DATE
1	4/16/26

**SENTRIGARD**  
METAL ROOFING SYSTEMS

PH: (434) 847-2445  
www.sentrigard.com

65 10TH STREET  
LYNCHBURG, VA 24504

SEAL:

SCOTT WOLTERS  
FL PE# 62354

WOLTERS ENGINEERING  
(CO.# 27194)  
15211 97TH ROAD N  
WEST PALM BEACH, FL 33412  
PH/FAX:(561) 225-1982

APR 16 2026  
PROFESSIONAL ENGINEER  
STATE OF FLORIDA  
No. 62354

DWG: **FP100SW-PUR**  
SHEET: **1/4**

# SENTRIGARD FP100 SERIES WALL PANELS

24 Ga. STEEL PANELS OVER 16 Ga. STEEL PURLINS

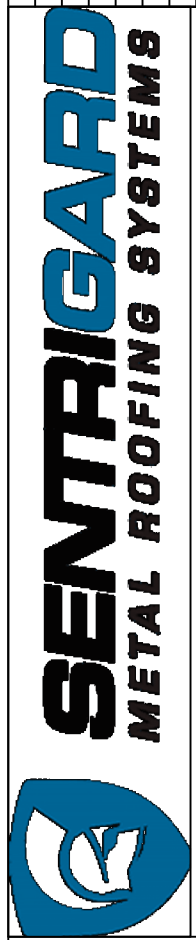
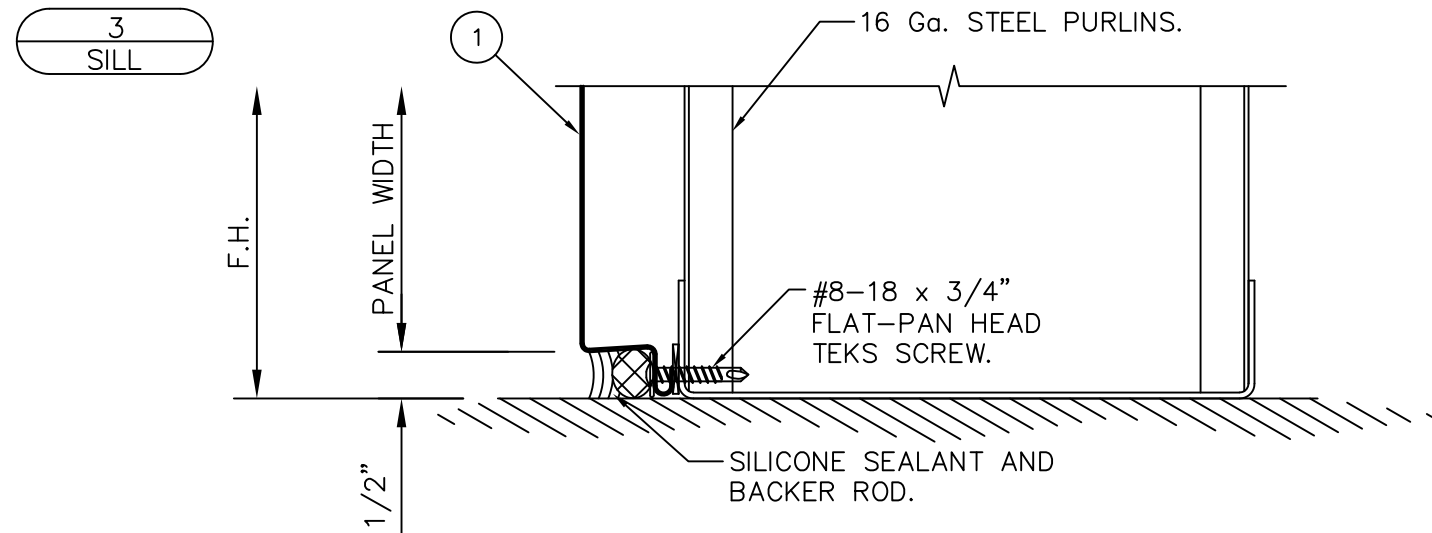
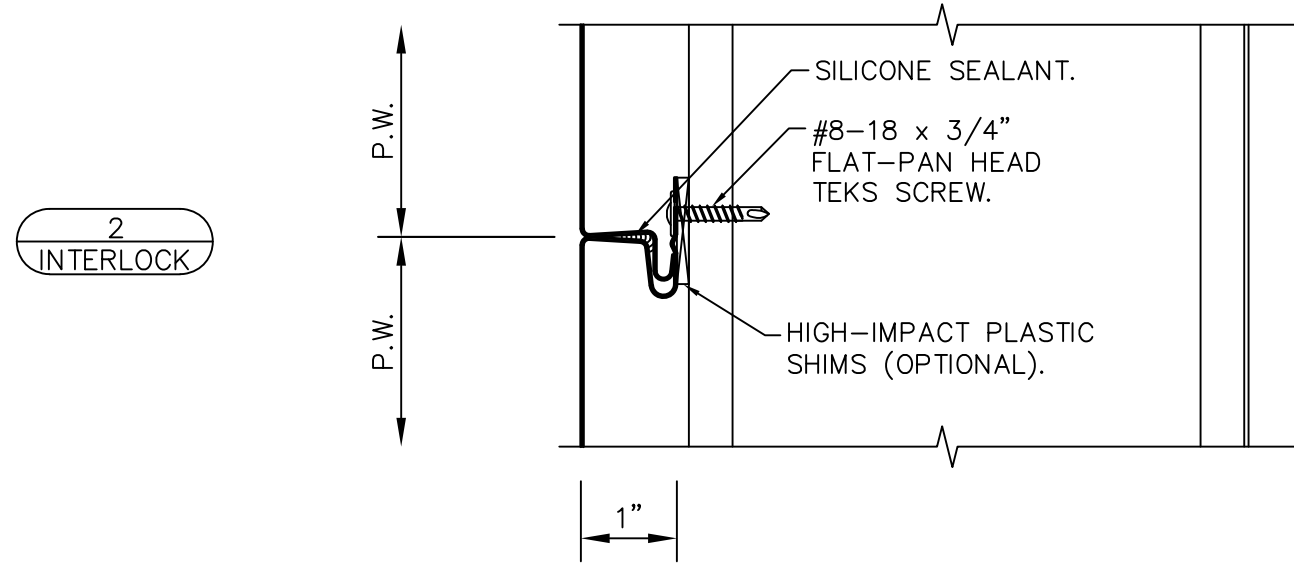
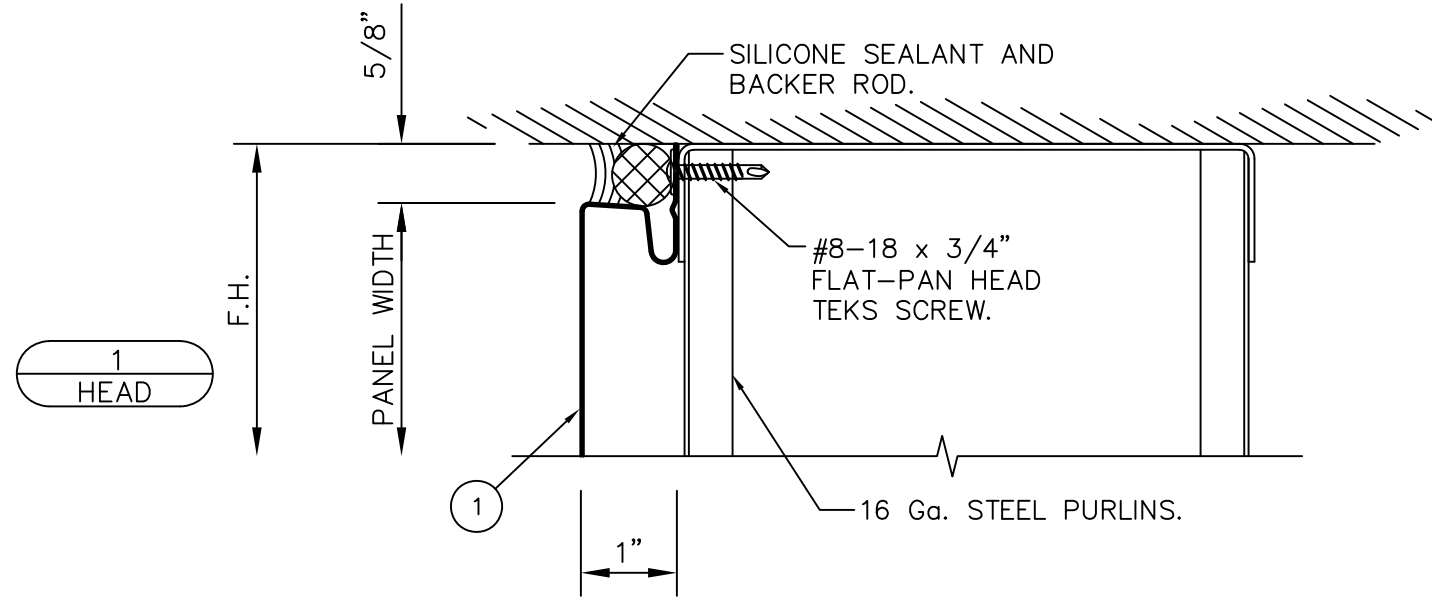

65 10TH STREET  
LYNCHBURG, VA 24504  
PH: (434) 847-2445  
www.sentrigard.com

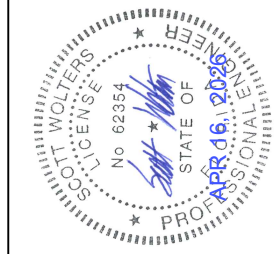

SEAL:  
SCOTT WOLTERS  
FL PE# 62354  
WOLTERS ENGINEERING  
(COA# 27194)  
15211 97TH ROAD N  
WEST PALM BEACH, FL 33412  
PH/FAX: (561) 225-1982

DWG: FP100SW-PUR  
SHEET: 2/4

REV.#	DATE
1	4/16/26
2	
3	
4	
5	
6	
7	
8	
9	
10	
11	
12	
13	
14	
15	
16	
17	
18	
19	
20	
21	
22	
23	
24	
25	
26	
27	
28	
29	
30	
31	
32	
33	
34	
35	
36	
37	
38	
39	
40	
41	
42	
43	
44	
45	
46	
47	
48	
49	
50	
51	
52	
53	
54	
55	
56	
57	
58	
59	
60	
61	
62	
63	
64	
65	
66	
67	
68	
69	
70	
71	
72	
73	
74	
75	
76	
77	
78	
79	
80	
81	
82	
83	
84	
85	
86	
87	
88	
89	
90	
91	
92	
93	
94	
95	
96	
97	
98	
99	
100	

# SENTRIGARD FP100 SERIES WALL PANELS

24 Ga. STEEL PANELS OVER 16 Ga. STEEL PURLINS

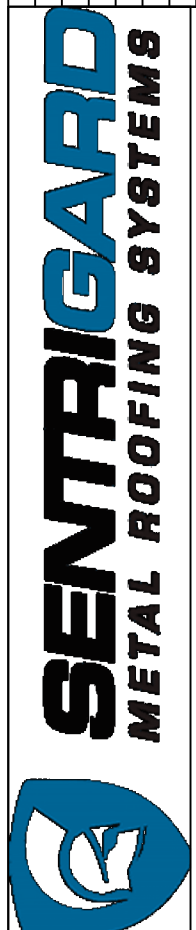
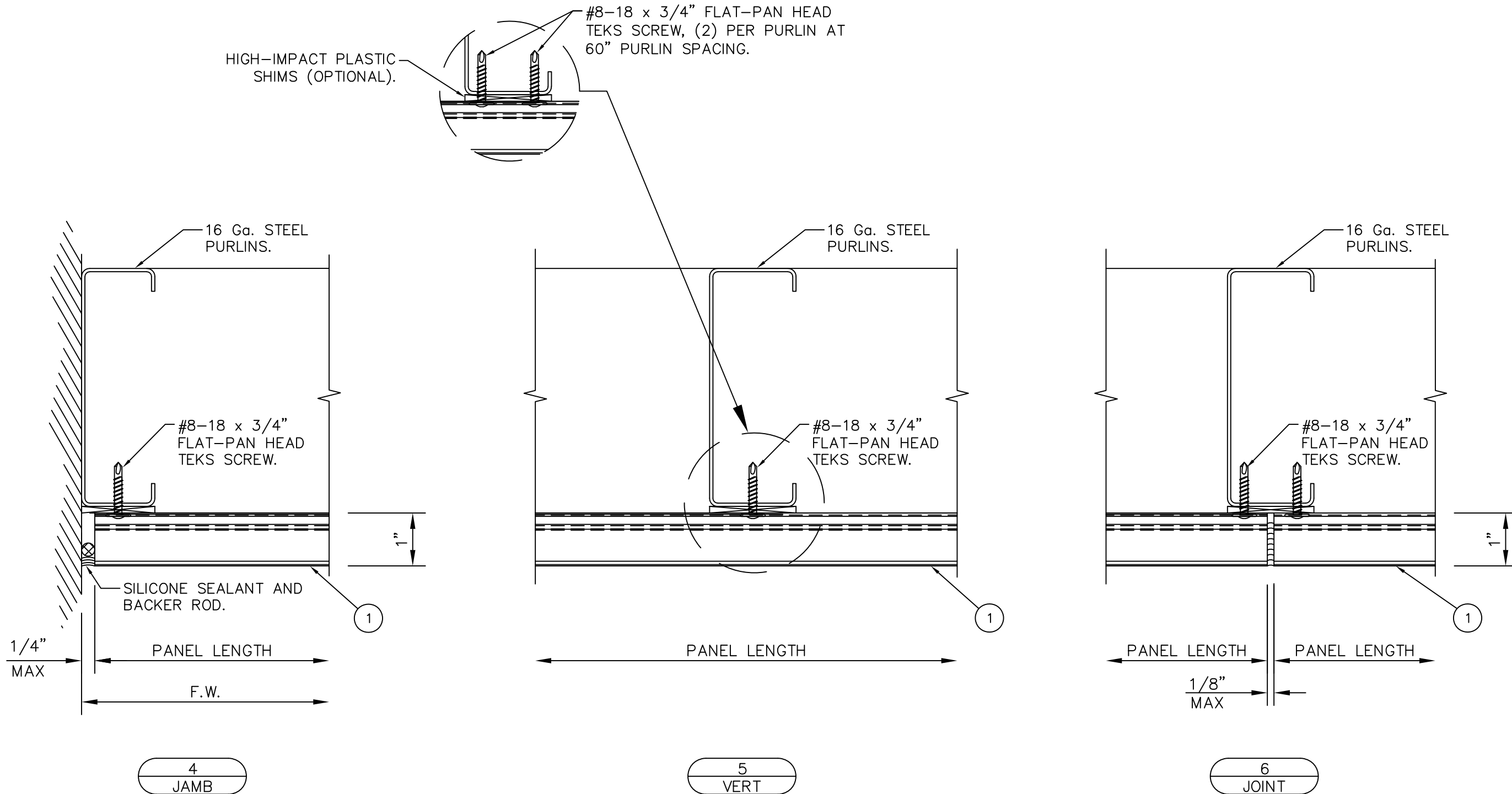

PH: (434) 847-2445  
www.sentrigard.com

65 10TH STREET  
LYNCHBURG, VA 24504

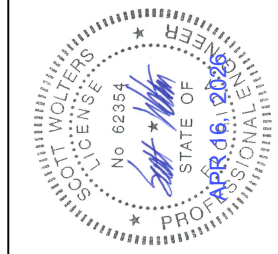

SEAL:  
SCOTT WALTERS  
FL PE# 62354  
WALTERS ENGINEERING  
(CO.# 27194)  
15211 97TH ROAD N  
WEST PALM BEACH, FL 33412  
PH/FAX: (561) 225-1982

DWG: **FP100SW-PUR**  
SHEET: **3/4**

REV.#	DATE
1ST SUBMITTAL	4/16/26
PRINTS ISSUED FOR	

# SENTRIGARD FP100 SERIES WALL PANELS

24 Ga. STEEL PANELS OVER 16 Ga. STEEL PURLINS

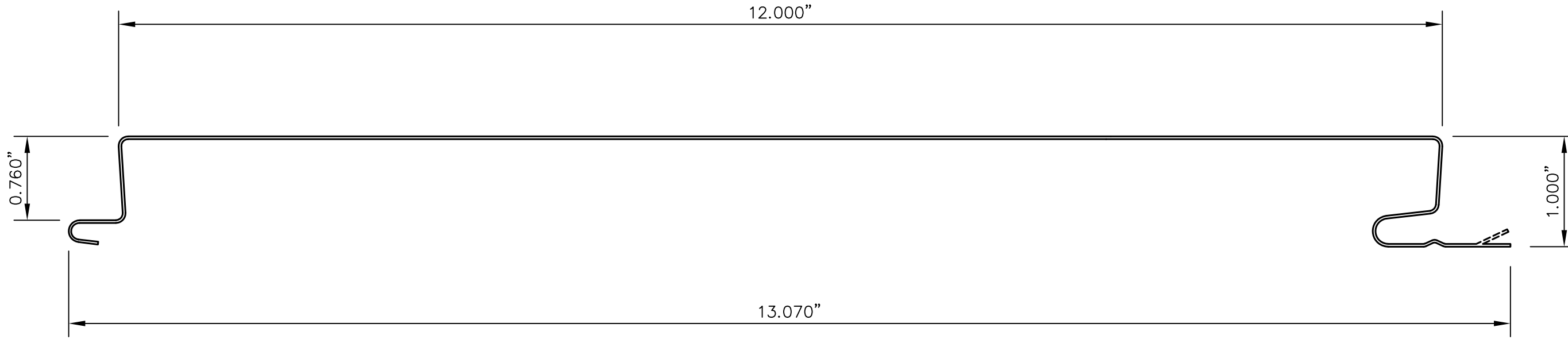

1

24 Ga. STEEL  
(Fy=61 ksi MIN)

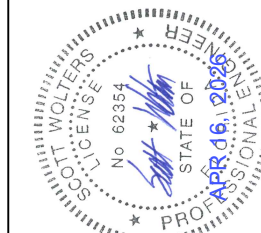

SEAL:  
SCOTT WOLTERS  
FL PE# 62354  
WOLTERS ENGINEERING  
(COA# 27194)  
15211 97TH ROAD N  
WEST PALM BEACH, FL 33412  
PH/FAX: (561) 225-1982

DWG: FP100SW-PUR  
SHEET: 4/4



**SENTRIGARD**  
METAL ROOFING SYSTEMS

65 10TH STREET  
LYNCHBURG, VA 24504

PH: (434) 847-2445  
www.sentrigard.com

REV.#	ISSUED FOR	DATE
1	1ST SUBMITTAL	4/16/26
2	PRINTS	
3		
4		
5		
6		
7		
8		
9		
10		